

12	YCN10111-PULSANTE START	YCN10111	1
11	YCN10121-PULSANTE STOP	YCN10121	1
10	TARGHETTA EMERGENZA	YCN10093	1
9	TOUCH SCREEN NB7W-TW01B	YL1E0146	1
8	GUARNIZIONE PANNELLO COMANDI	YPR20509	1
7	CAPPUCCIO STAGNO	YL000373	3
6	RESET CON SPIA	YCN10105	1
5	PORTALAMPADA 3SB3400-1A	YY031033	1
4	CONTATTO NO 3SB3400-0B	YY031036	2
3	FUNGO EMERGENZA	YY031020	1
2	CONTATTO NC 3SB3400-0C	YY031037	2
1	FRONTALINO OMRON	YPR20523-R3	1
Pos.	DESCRIZIONE ARTICOLO	CODICE ARTICOLO	Qtà

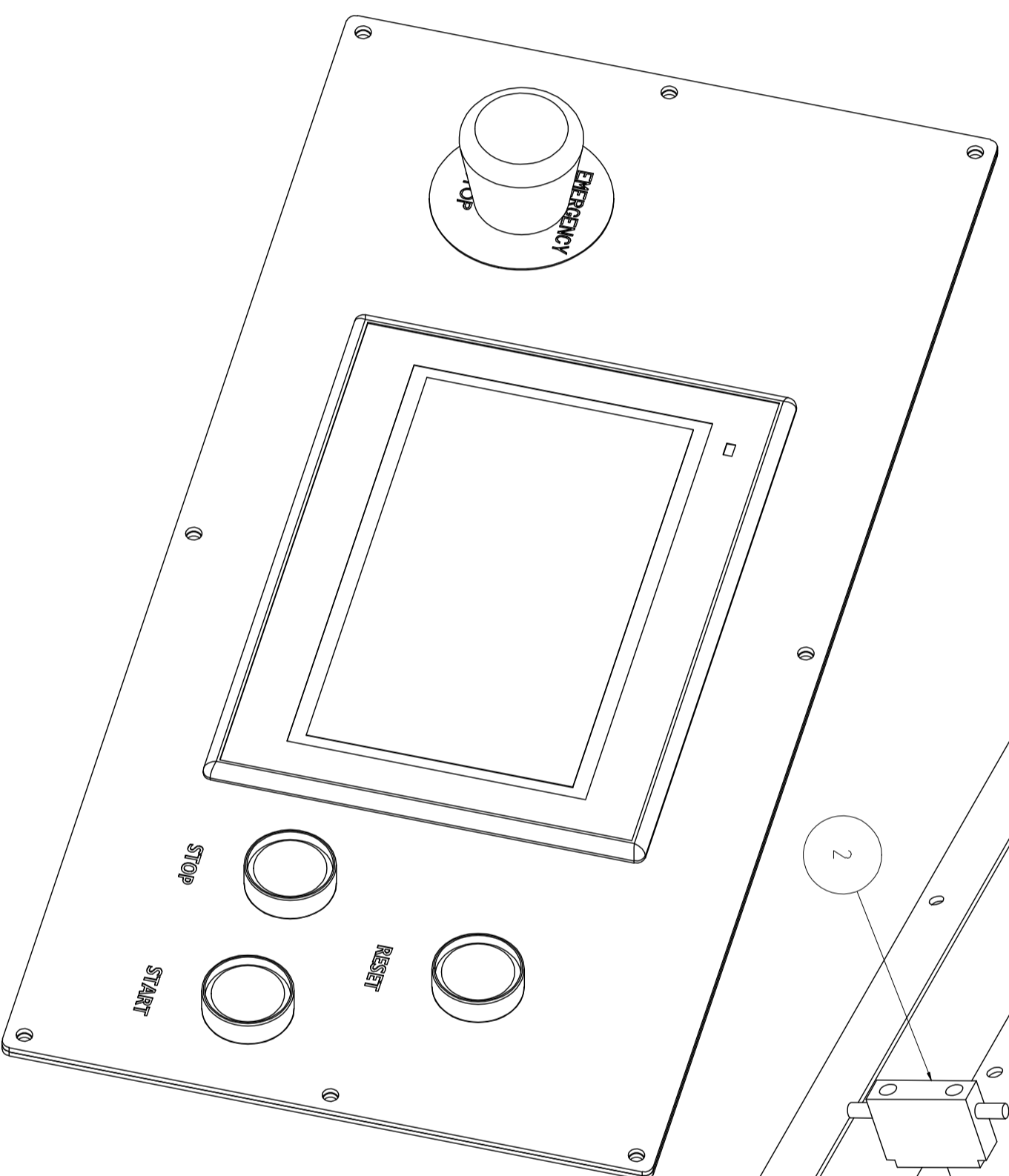
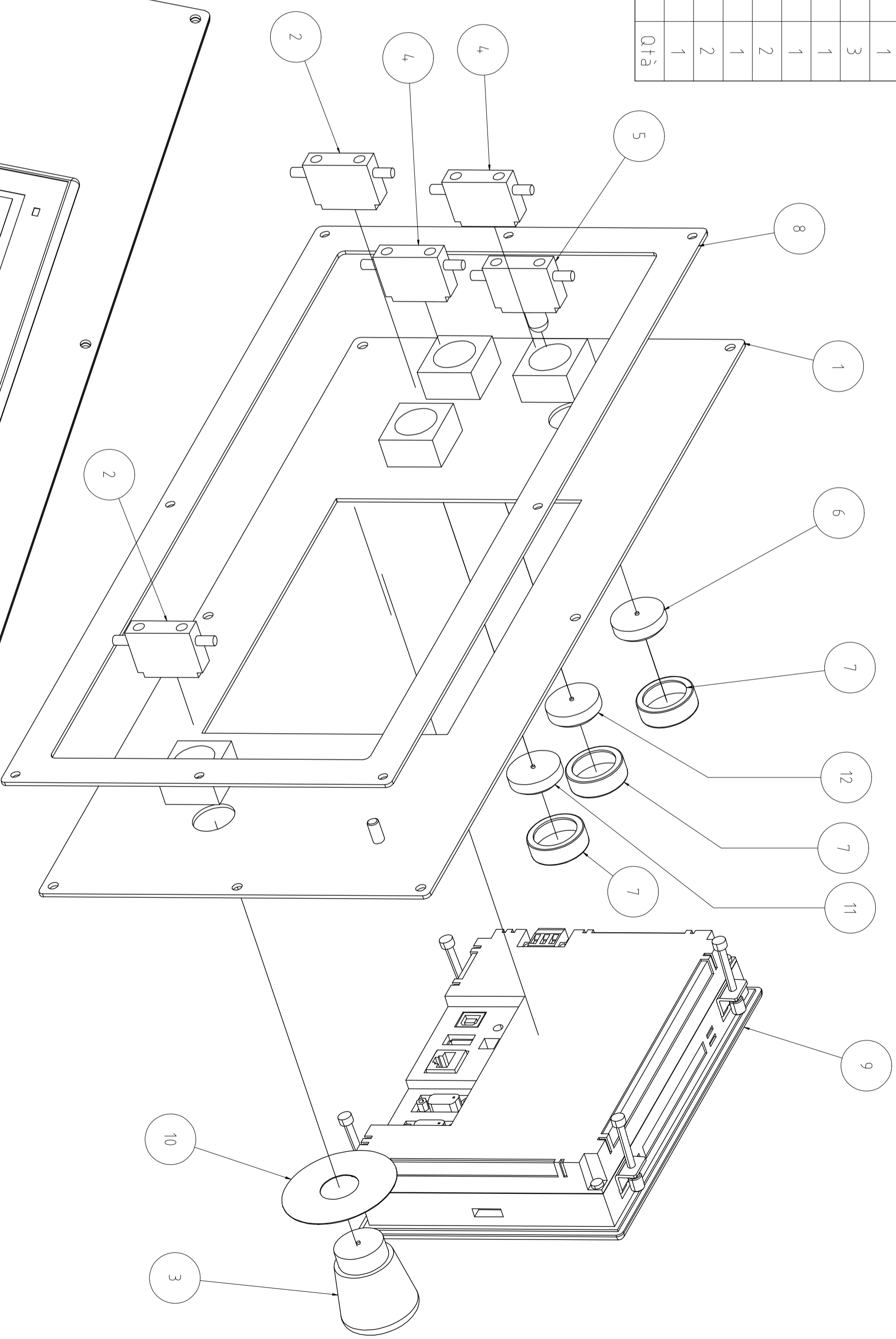
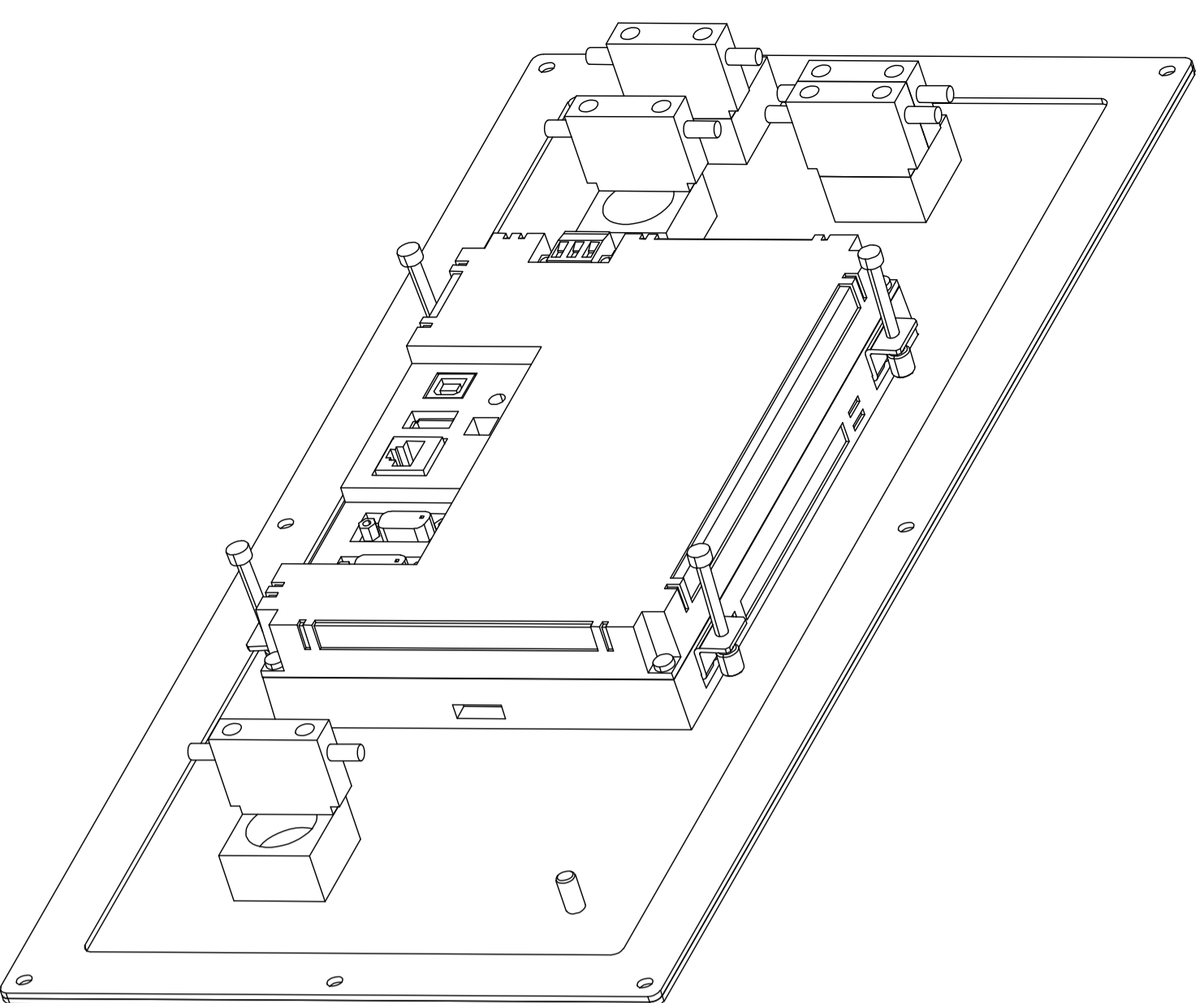

<b>Italian Pack</b> Via Al Bassone 30 22100 Como -Italy Tel. (+39) 031 888011 Fax. (+39) 031 888050 www.italianpack.com		GRUPPO / Group: <b>PANN OPERATORE TOUCH 7"</b>		MACCHINA / Machine: <b>PERSEUS</b>		DESIGN / Des: M.P.F.		DATA / Date: 15/04/2016		COMPLESSA Work order: A2	
REVISIONE / Description Revision		CLIENTE / Customer:		DESIGNATORE Designer:		DATA / Date ORO / Order:		SCALA / Scale:		FOLGIO / Sheet:	
STANDARD / OPTIONAL / SPECIAL <b>STANDARD</b>		DESIGN / Drawing: <b>PRB00035C</b>		REV / Revision:		N° FOGLIO / N° Sheet: <b>(1 / 1)</b>		CI RISERVIAMO LA PROPRIETA' A TERMINE DI LEGGE DI QUESTO DISEGNO CON DIVIETO DI RIPRODURLO ANCHE IN PARTE O DI COMUNICARLO A TERZI SENZA LA NOSTRA AUTORIZZAZIONE. We reserve the property of this drawing according to rules in force and it is avoided to reproduce or transmit it to third part without our previous authorisation.			